

16M-BIT CMOS MOBILE SPECIFIED RAM

1M-WORD BY 16-BIT

EXTENDED TEMPERATURE OPERATION

Description

The μ PD4616112-X is a high speed, low power, 16,777,216 bits (1,048,576 words by 16 bits) CMOS mobile specified RAM featuring low power static RAM compatible function and pin configuration.

The μ PD4616112-X is fabricated with advanced CMOS technology using one-transistor memory cell.

The μ PD4616112-X is packed in 48-pin TAPE FBGA.

Features

- 1,048,576 words by 16 bits organization
- Fast access time: 85, 95 ns (MAX.)
- Byte data control: /LB (I/O0 - I/O7), /UB (I/O8 - I/O15)
- Low voltage operation: $V_{CC} = 2.6$ to 3.1 V
- Operating ambient temperature: $T_A = -25$ to $+85$ °C
- Output Enable input for easy application
- Chip Enable input: /CS pin
- Standby Mode input: MODE pin
- Standby Mode1: Normal standby (Memory cell data hold valid)
- Standby Mode2: Memory cell data hold invalid

Product name	Access time ns (MAX.)	Operating supply Voltage	Operating ambient temperature °C	Supply current	
				At operating mA (MAX.)	At standby μ A (MAX.)
μ PD4616112-BxxLX	85, 95	2.6 to 3.1	-25 to +85	35	70 / 10

The information in this document is subject to change without notice. Before using this document, please confirm that this is the latest version.
Not all devices/types available in every country. Please check with local NEC representative for availability and additional information.

Ordering Information

Part number	Package	Access time ns (MAX.)	Operating supply voltage V	Operating temperature °C	Remark
μPD4616112F9-B85LX-BC2	48-pin TAPE FBGA (8 x 6)	85	2.6 to 3.1	-25 to +85	B version
μPD4616112F9-B95LX-BC2		95			

Marking Image

Part number	Marking (XX)
μPD4616112F9-B85LX-BC2	L1
μPD4616112F9-B95LX-BC2	L2

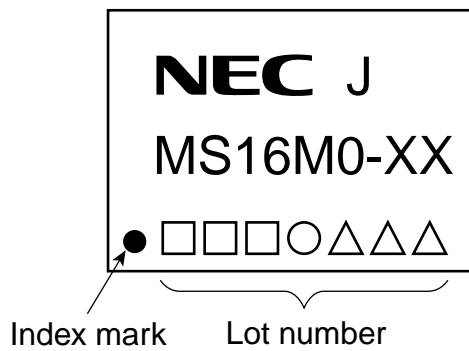

Pin Configuration

/xxx indicates active low signal.

48-pin TAPE FBGA (8 x 6)

Top View

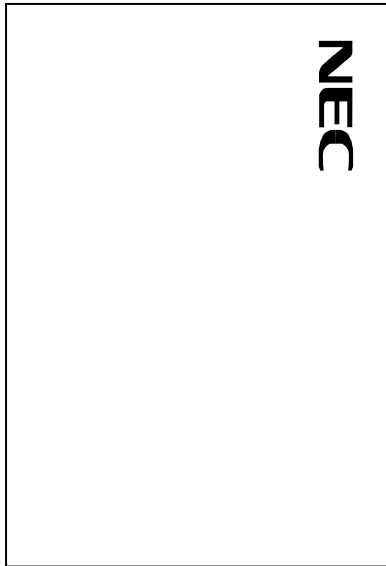

1 2 3 4 5 6

Bottom View

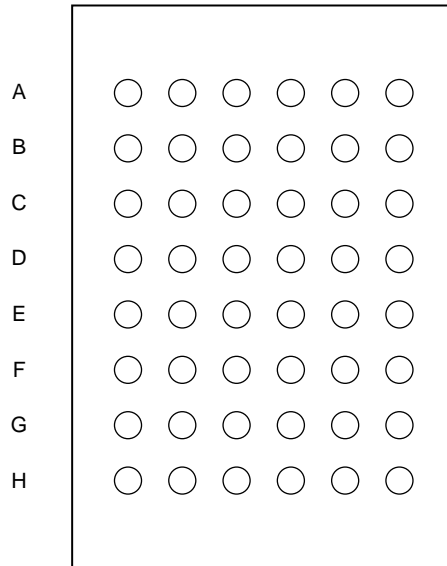

6 5 4 3 2 1

	1	2	3	4	5	6
A	/LB	/OE	A0	A1	A2	MODE
B	I/O8	/UB	A3	A4	/CS	I/O0
C	I/O9	I/O10	A5	A6	I/O1	I/O2
D	GND	I/O11	A17	A7	I/O3	V _{cc}
E	V _{cc}	I/O12	GND	A16	I/O4	GND
F	I/O14	I/O13	A14	A15	I/O5	I/O6
G	I/O15	A19	A12	A13	/WE	I/O7
H	A18	A8	A9	A10	A11	GND

	6	5	4	3	2	1
A	MODE	A2	A1	A0	/OE	/LB
B	I/O0	/CS	A4	A3	/UB	I/O8
C	I/O2	I/O1	A6	A5	I/O10	I/O9
D	V _{cc}	I/O3	A7	A17	I/O11	GND
E	GND	I/O4	A16	GND	I/O12	V _{cc}
F	I/O6	I/O5	A15	A14	I/O13	I/O14
G	I/O7	/WE	A13	A12	A19	I/O15
H	GND	A11	A10	A9	A8	A18

- A0 - A19 : Address inputs
- I/O0 - I/O15 : Data inputs / outputs
- /CS : Chip Select
- MODE : Standby mode
- /WE : Write enable

- /OE : Output enable
- /LB, /UB : Byte data select
- V_{cc} : Power supply
- GND : Ground

Remark Refer to **Package Drawing** for the index mark.

★ Truth Table

/CS	MODE	/OE	/WE	/LB	/UB	Mode	I/O		Supply current	
							I/O0 - I/O7	I/O8 - I/O15		
H	H	x	x	x	x	Not selected (Standby Mode 1)	High impedance	High impedance	I _{SB1}	
H	L	x	x	x	x	Not selected (Standby Mode 2)	High impedance	High impedance	I _{SB2}	
L	H	H	H	x	x	Output disable	High impedance	High impedance	I _{CCA}	
				L	L	Word read	D _{OUT}	D _{OUT}		
				L	H	Lower byte read	D _{OUT}	High impedance		
				H	L	Upper byte read	High impedance	D _{OUT}		
	x	L	L	L	L	L	Word write	D _{IN}		D _{IN}
					L	H	Lower byte write	D _{IN}		High impedance
					H	L	Upper byte write	High impedance		D _{IN}
					H	H	Write abort	High impedance		High impedance

Caution MODE pin must be fixed to High except Standby Mode 2.

Remark x: V_{IH} or V_{IL}

Initialization

The μPD4616112-X is initialized in the power-on sequence according to the following.

- (1) To stabilize internal circuits, before turning on the power, a 200 μs or longer wait time must precede any signal toggling.
- (2) After the wait time, read operation must be performed at least 3 times. After that, it can be normal operation.

Initialization Timing Chart

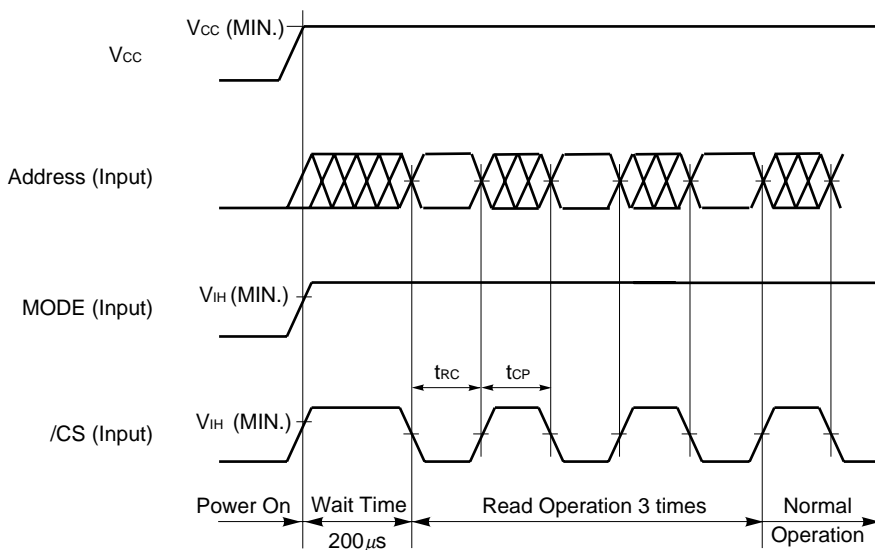

- Cautions**
1. Following power application, make MODE and /CS high level during the wait time interval.
 2. Following power application, make MODE high level during the wait time and three read operations.
 3. The read operation must satisfy the specs described on page 10 (Read Cycle (B Version)).
 4. The address is don't care (V_{IH} or V_{IL}) during read operation.
 5. Read operation must be executed with toggled the /CS pin.
 6. To prevent bus contention, it is recommended to set /OE to high level.
 7. Do not input data to the I/O pins if /OE is low level during a read operation.

Electrical Specifications

Absolute Maximum Ratings

Parameter	Symbol	Condition	Rating	Unit
Supply voltage	V _{CC}		-0.5 ^{Note} to +3.3	V
Input / Output voltage	V _T		-0.5 ^{Note} to V _{CC} + 0.4 (3.3 V MAX).	V
Operating ambient temperature	T _A		-25 to +85	°C
Storage temperature	T _{stg}		-55 to +125	°C

Note -1.0 V (MIN.) (Pulse width: 30 ns)

Caution Exposing the device to stress above those listed in Absolute Maximum Rating could cause permanent damage. The device is not meant to be operated under conditions outside the limits described in the operational section of this specification. Exposure to Absolute Maximum Rating conditions for extended periods may affect device reliability.

Recommended Operating Conditions

Parameter	Symbol	Condition	μPD4616112-BxxLX		Unit
			MIN.	MAX.	
Supply voltage	V _{CC}		2.6	3.1	V
High level input voltage	V _{IH}		0.8 V _{CC}	V _{CC} +0.3	V
Low level input voltage	V _{IL}		-0.3 ^{Note}	0.2 V _{CC}	V
Operating ambient temperature	T _A		-25	+85	°C

Note -0.5 V (MIN.) (Pulse width: 30 ns)

Capacitance (T_A = 25°C, f = 1 MHz)

Parameter	Symbol	Test condition	MIN.	TYP.	MAX.	Unit
Input capacitance	C _{IN}	V _{IN} = 0 V			8	pF
Input / Output capacitance	C _{I/O}	V _{I/O} = 0 V			10	pF

- Remarks**
- V_{IN}: Input voltage
V_{I/O}: Input / Output voltage
 - These parameters are not 100% tested.

DC Characteristics (Recommended Operating Conditions Unless Otherwise Noted)

Parameter	Symbol	Test condition	μPD4616112-BxxLX			Unit
			MIN.	TYP.	MAX.	
Input leakage current	I _{LI}	V _{IN} = 0 V to V _{CC}	-1.0		+1.0	μA
I/O leakage current	I _{LO}	V _{I/O} = 0 V to V _{CC} , /CS = V _{IH} or /WE = V _{IL} or /OE = V _{IH}	-1.0		+1.0	μA
Operating supply current	I _{CCA}	/CS = V _{IL} , Minimum cycle time, I _{I/O} = 0 mA			35	mA
Standby supply current	I _{SB1}	/CS ≥ V _{CC} - 0.2 V, MODE ≥ V _{CC} - 0.2 V			70	μA
	I _{SB2}	/CS ≥ V _{CC} - 0.2 V, MODE ≤ 0.2 V			10	
High level output voltage	V _{OH}	I _{OH} = -0.5 mA	0.8 V _{CC}			V
Low level output voltage	V _{OL}	I _{OL} = 1 mA			0.2 V _{CC}	V

Remarks 1. V_{IN}: Input voltage

V_{I/O}: Input / Output voltage

2. These DC characteristics are in common regardless of product classifications.

Standby Mode State Machine

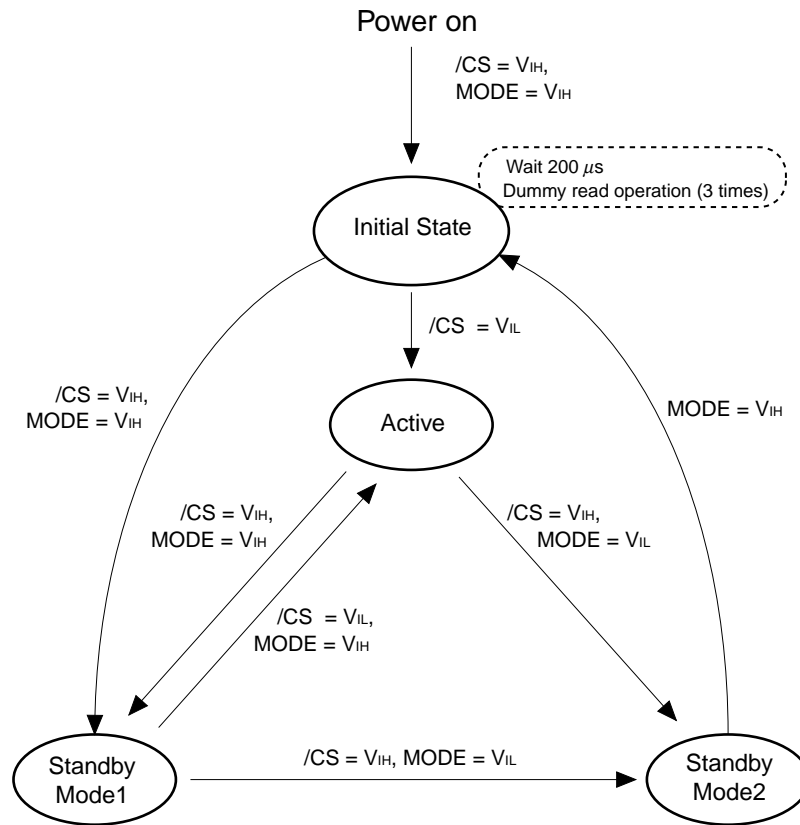

Standby Mode Characteristics

Standby Mode	Memory Cell Data Hold	Standby Supply Current (μA)
Mode 1	Valid	70 (I _{SB1})
Mode 2	Invalid	10 (I _{SB2})

AC Characteristics (Recommended Operating Conditions Unless Otherwise Noted)

AC Test Conditions

[μ PD4616112-B85LX, μ PD4616112-B95LX]

Input Waveform (Rise and Fall Time ≤ 5 ns)

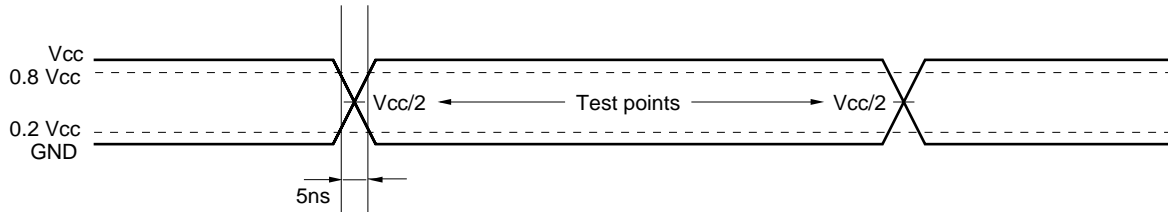

Output Waveform

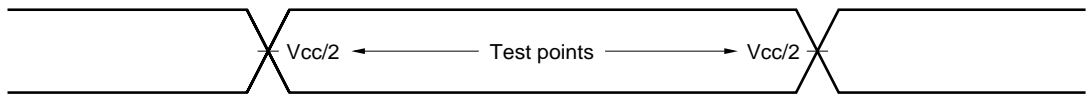

Output Load

AC characteristics directed with the note should be measured with the output load shown in **Figure 1**.

Figure 1

CL: 50 pF

5 pF (tCLZ, tOLZ, tBLZ, tCHZ, tOHZ, tBHZ, tWHZ, tOW)

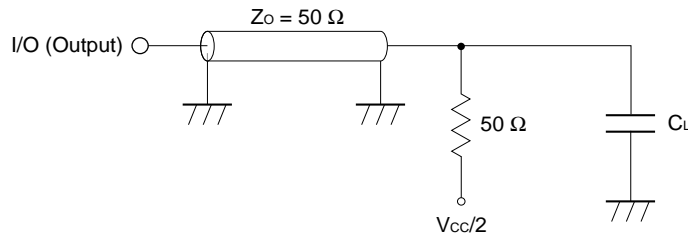

Read Cycle (B version)

Parameter	Symbol	μPD4616112-B85LX		μPD4616112-B95LX		Unit	Note
		MIN.	MAX.	MIN.	MAX.		
Read cycle time	t _{RC}	85	10,000	95	10,000	ns	1
Identical address read cycle time	t _{RC1}	85	10,000	95	10,000	ns	2
Address skew time	t _{SKEW}		10		20	ns	3
/CS pulse width	t _{CP}	10		10		ns	
Address access time	t _{AA}		85		95	ns	4
/CS access time	t _{ACS}		85		95	ns	
/OE to output valid	t _{OE}		35		40	ns	5
/LB, /UB to output valid	t _{BA}		35		40	ns	
Output hold from address change	t _{OH}	10		10		ns	
/CS to output in low impedance	t _{CLZ}	10		10		ns	
/OE to output in low impedance	t _{OLZ}	5		5		ns	
/LB, /UB to output in low impedance	t _{BLZ}	5		5		ns	
/CS to output in high impedance	t _{CHZ}		25		25	ns	
/OE to output in high impedance	t _{OHZ}		25		25	ns	
/LB, /UB to output in high impedance	t _{BHZ}		25		25	ns	

- Notes 1.** One read cycle (t_{RC}) must satisfy the minimum value (t_{RC(MIN.)}) and maximum value (t_{RC(MAX.)} = 10 μs). t_{RC} indicates the time from the /CS low level input point or address change start point, whichever is later, to the /CS high level input point or the next address change start point, whichever is earlier. As a result, there are the following four conditions for t_{RC}.
- 1) Time from address change start point to /CS high level input point (address access)
 - 2) Time from address change start point to next address change start point (address access)
 - 3) Time from /CS low level input point to next address change start point (/CS access)
 - 4) Time from /CS low level input point to /CS high level input point (/CS access)
- 2.** The identical address read cycle time (t_{RC1}) is the cycle time of one read operation when performing continuous read operations toggling /OE, /LB, and /UB with the address fixed and /CS low level. Perform settings so that the sum (t_{RC}) of the identical address read cycle times (t_{RC1}) is 10 μs or less.
- 3.** t_{SKEW} indicates the following three types of time depending on the condition.
- 1) When switching /CS from high level to low level, t_{SKEW} is the time from the /CS low level input point until the next address is determined.
 - 2) When switching /CS from low level to high level, t_{SKEW} is the time from the address change start point to the /CS high level input point.
 - 3) When /CS is fixed to low level, t_{SKEW} is the time from the address change start point until the next address is determined.
- Since specs are defined for t_{SKEW} only when /CS is active, t_{SKEW} is not subject to limitations when /CS is switched from high level to low level following address determination, or when the address is changed after /CS is switched from low level to high level.
- 4.** Regarding t_{AA} and t_{ACS}, only t_{AA} is satisfied during address access (refer to 1) and 2) of **Note 1**), and only t_{ACS} is satisfied during /CS access (refer to 3) of **Note 1**).
- 5.** Regarding t_{BA} and t_{OE}, only t_{BA} is satisfied if /OE becomes active later than /UB and /LB, and only t_{OE} is satisfied if /UB and /LB become active before /OE.

Read Cycle Timing Chart 1

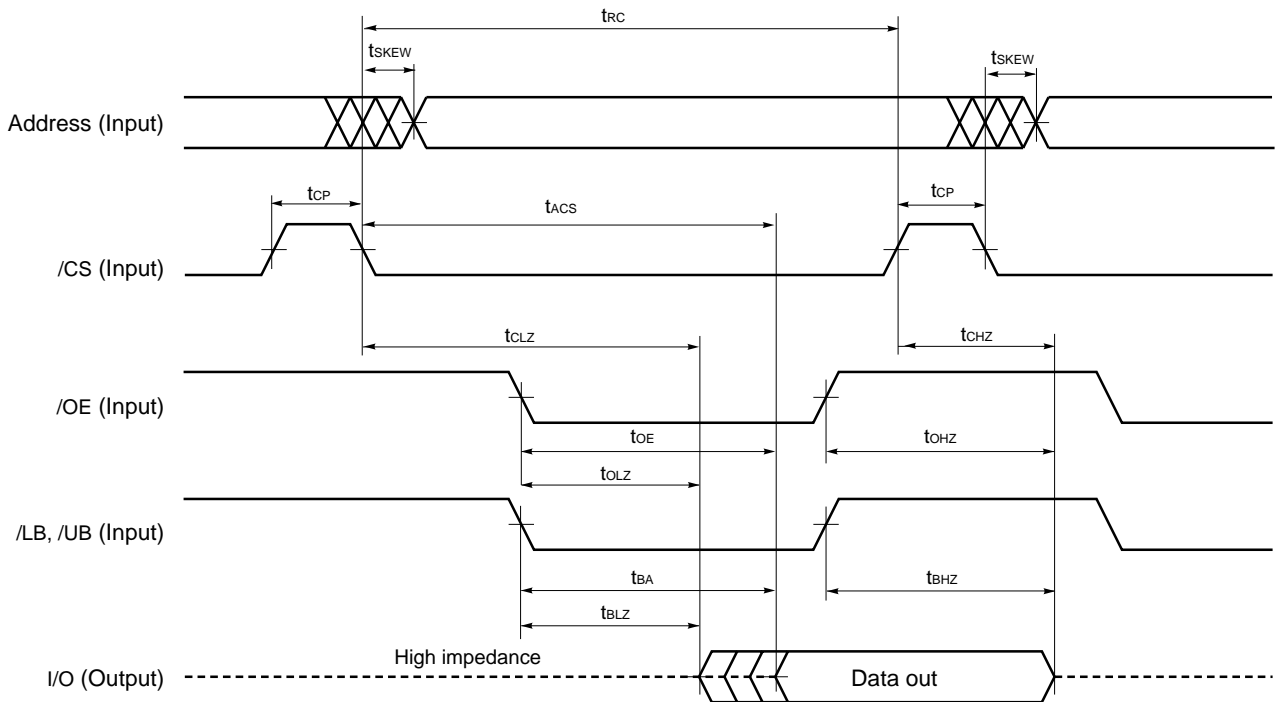
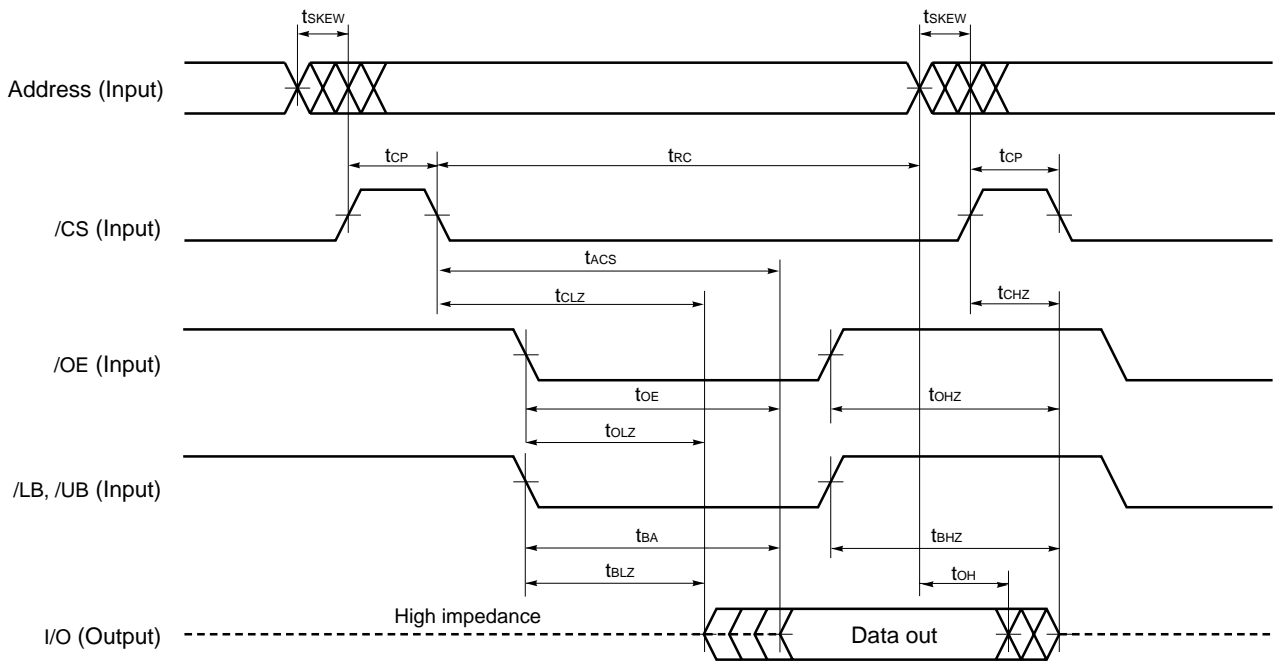

Caution If the address is changed using a value that is either lower than the minimum value or higher than the maximum value for the read cycle time (t_{RC}), none of the data can be guaranteed.

Remark In read cycle, /WE should be fixed to High.

Read Cycle Timing Chart 2

Data Sheet M15794EJ2V0DS

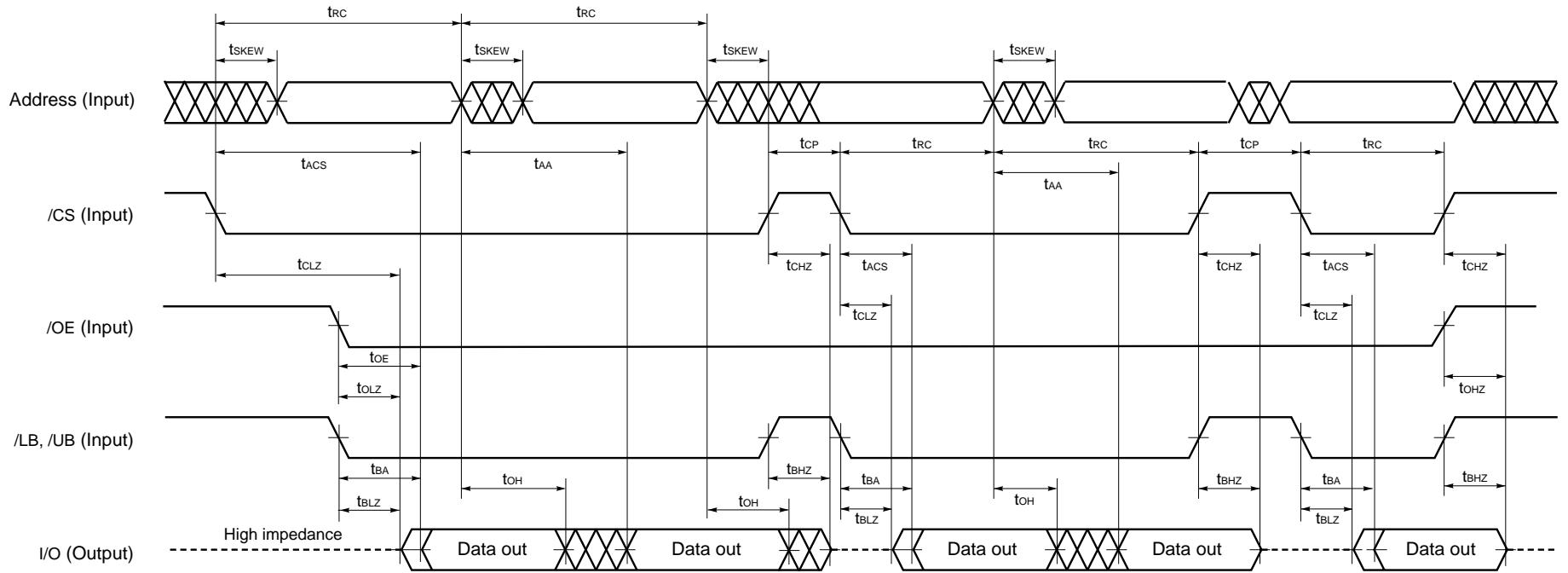

Caution If the address is changed using a value that is either lower than the minimum value or higher than the maximum value for the read cycle time (t_{RC}), none of the data can be guaranteed.

Remark In read cycle, /WE should be fixed to High.

Read Cycle Timing Chart 3

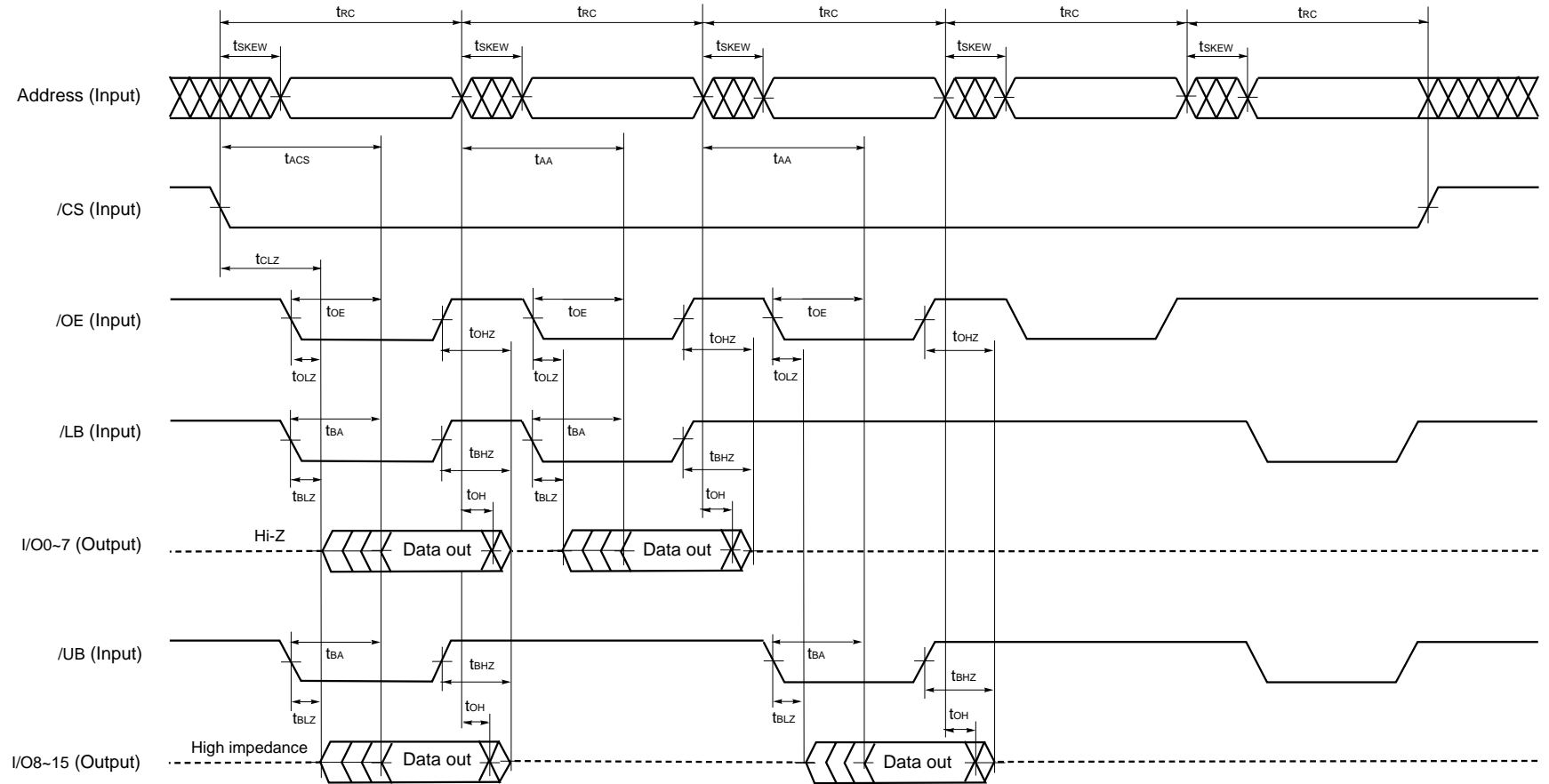

Caution If the address is changed using a value that is either lower than the minimum value or higher than the maximum value for the read cycle time (t_{RC}), none of the data can be guaranteed.

Remark In read cycle, $/WE$ should be fixed to High.

Read Cycle Timing Chart 4

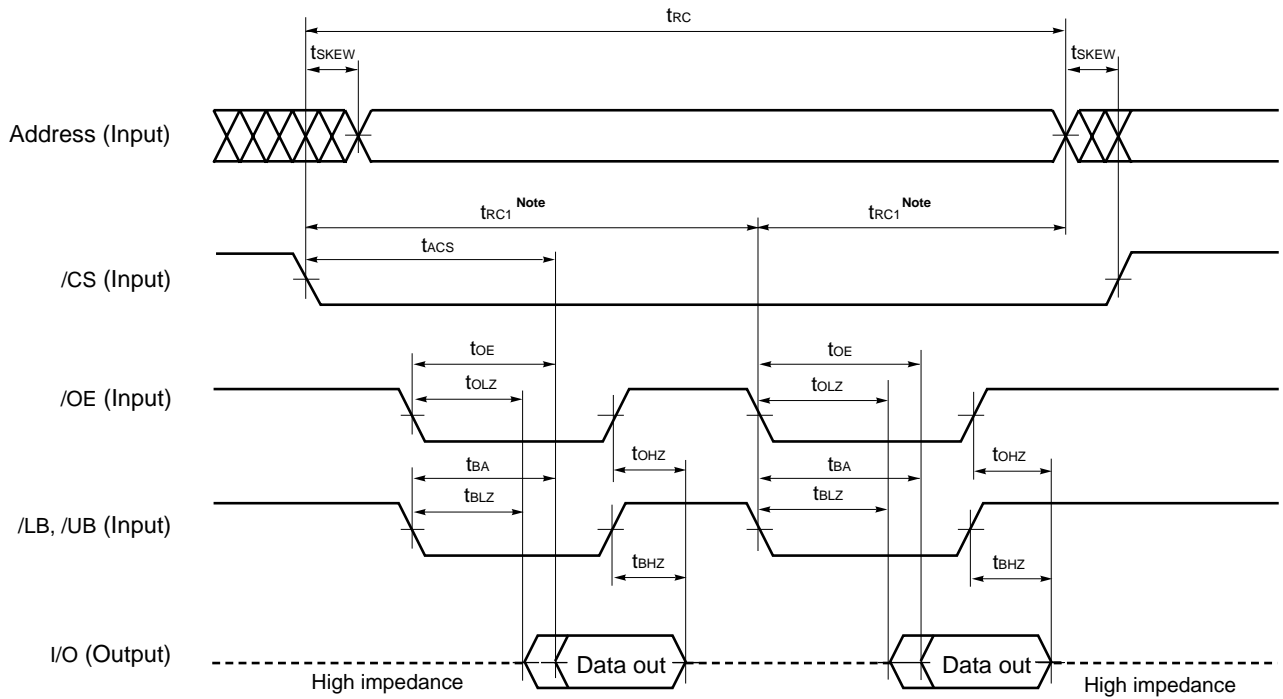

Caution If the address is changed using a value that is either lower than the minimum value or higher than the maximum value for the read cycle time (t_{RC}), none of the data can be guaranteed.

Note To perform a continuous read toggling /OE, /UB, and /LB with /CS low level at an identical address, make settings so that the sum (t_{RC}) of the identical address read cycle times (t_{RC1}) is 10 μs or less.

Remark In read cycle, /WE should be fixed to High.

Write Cycle (B version)

Parameter	Symbol	μPD4616112-B85LX		μPD4616112-B95LX		Unit	Note
		MIN.	MAX.	MIN.	MAX.		
Write cycle time	t _{WC}	85	10,000	95	10,000	ns	1
Identical address write cycle time	t _{WC1}	85	10,000	95	10,000	ns	2
Address skew time	t _{SKEW}		10		20	ns	3
/CS to end of write	t _{CW}	40		50		ns	4
/LB, /UB to end of write	t _{BW}	30		35		ns	
Address valid to end of write	t _{AW}	35		45		ns	
Write pulse width	t _{WP}	30		35		ns	
Write recovery time	t _{WR}	20		20		ns	5
/CS pulse width	t _{CP}	10		10		ns	
Address setup time	t _{AS}	0		0		ns	
Byte write hold time	t _{BWH}	20		20		ns	
Data valid to end of write	t _{DW}	20		25		ns	
Data hold time	t _{DH}	0		0		ns	
/OE to output in low impedance	t _{OLZ}	5		5		ns	
/WE to output in high impedance	t _{WHZ}		25		25	ns	
/OE to output in high impedance	t _{OHZ}		25		25	ns	
Output active from end of write	t _{OW}	5		5		ns	

Notes 1. One write cycle (t_{WC}) must satisfy the minimum value (t_{WC(MIN.)}) and the maximum value (t_{WC(MAX.)} = 10 μs).

t_{WC} indicates the time from the /CS low level input point or address change start point, whichever is after, to the /CS high level input point or the next address change start point, whichever is earlier. As a result, there are the following four conditions for t_{WC}.

- 1) Time from address change start point to /CS high level input point
 - 2) Time from address change start point to next address change start point
 - 3) Time from /CS low level input point to next address change start point
 - 4) Time from /CS low level input point to /CS high level input point
- 2.** The identical address read cycle time (t_{WC1}) is the cycle time of one write cycle when performing continuous write operations with the address fixed and /CS low level, changing /LB and /UB at the same time, and toggling /WE, as well as when performing a continuous write toggling /LB and /UB. Make settings so that the sum (t_{WC}) of the identical address write cycle times (t_{WC1}) is 10 μs or less.
- 3.** t_{SKEW} indicates the following three types of time depending on the condition.
- 1) When switching /CS from high level to low level, t_{SKEW} is the time from the /CS low level input point until the next address is determined.
 - 2) When switching /CS from low level to high level, t_{SKEW} is the time from the address change start point to the /CS high level input point.
 - 3) When /CS is fixed to low level, t_{SKEW} is the time from the address change start point until the next address is determined.

Since specs are defined for t_{SKEW} only when /CS is active, t_{SKEW} is not subject to limitations when /CS is switched from high level to low level following address determination, or when the address is changed after /CS is switched from low level to high level.

4. Definition of write start and write end

	/CS	/WE	/LB, /UB	Status
Write start pattern 1	H to L	L	L	If /WE, /LB, /UB are low level, time when /CS changes from high level to low level
Write start pattern 2	L	H to L	L	If /CS, /LB, /UB are low level, time when /WE changes from high level to low level
Write start pattern 3	L	L	H to L	If /CS, /WE are low level, time when /LB or /UB changes from high level to low level
Write end pattern 1	L	L to H	L	If /CS, /WE, /LB, /UB are low level, time when /WE changes from low level to high level
Write end pattern 2	L	L	L to H	When /CS, /WE, /LB, /UB are low level, time when /LB or /UB changes from low level to high level

5. Definition of write end recovery time (t_{WR})

- 1) Time from write end to address change start point, or from write end to /CS high level input point
- 2) When /CS, /LB, /UB are low level and continuously written to the identical address, time from /WE high level input point to /WE low level input point
- 3) When /CS, /WE are low level and continuously written to the identical address, time from /LB or /UB high level input point, whichever is later, to /LB or /UB low level input point, whichever is earlier.
- 4) When /CS is low level and continuously written to the identical address, time from write end to point at which /WE, /LB, or /UB starts to change from high level to low level, whichever is earliest.

Write Cycle Timing Chart 1

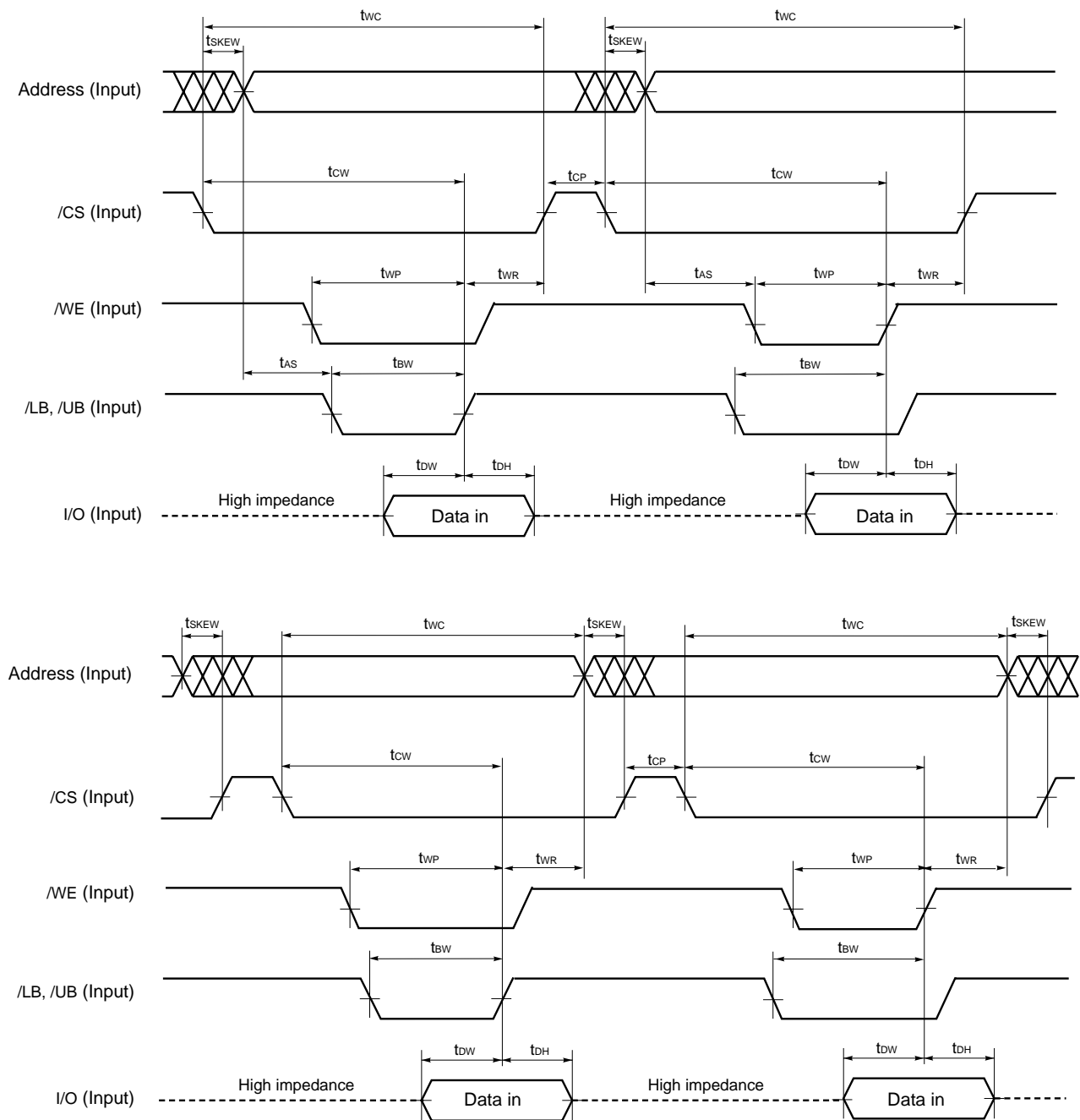

- Cautions**
1. During address transition, at least one of pins /CS, /WE should be inactivated.
 2. Do not input data to the I/O pins while they are in the output state.
 3. If the address is changed using a value that is either lower than the minimum value or higher than the maximum value for the write cycle time (tcw), none of the data can be guaranteed.

Remark Write operation is done during the overlap time of a Low /CS, /WE, /LB and/or /UB.

★ Write Cycle Timing Chart 2 (/WE Controlled)

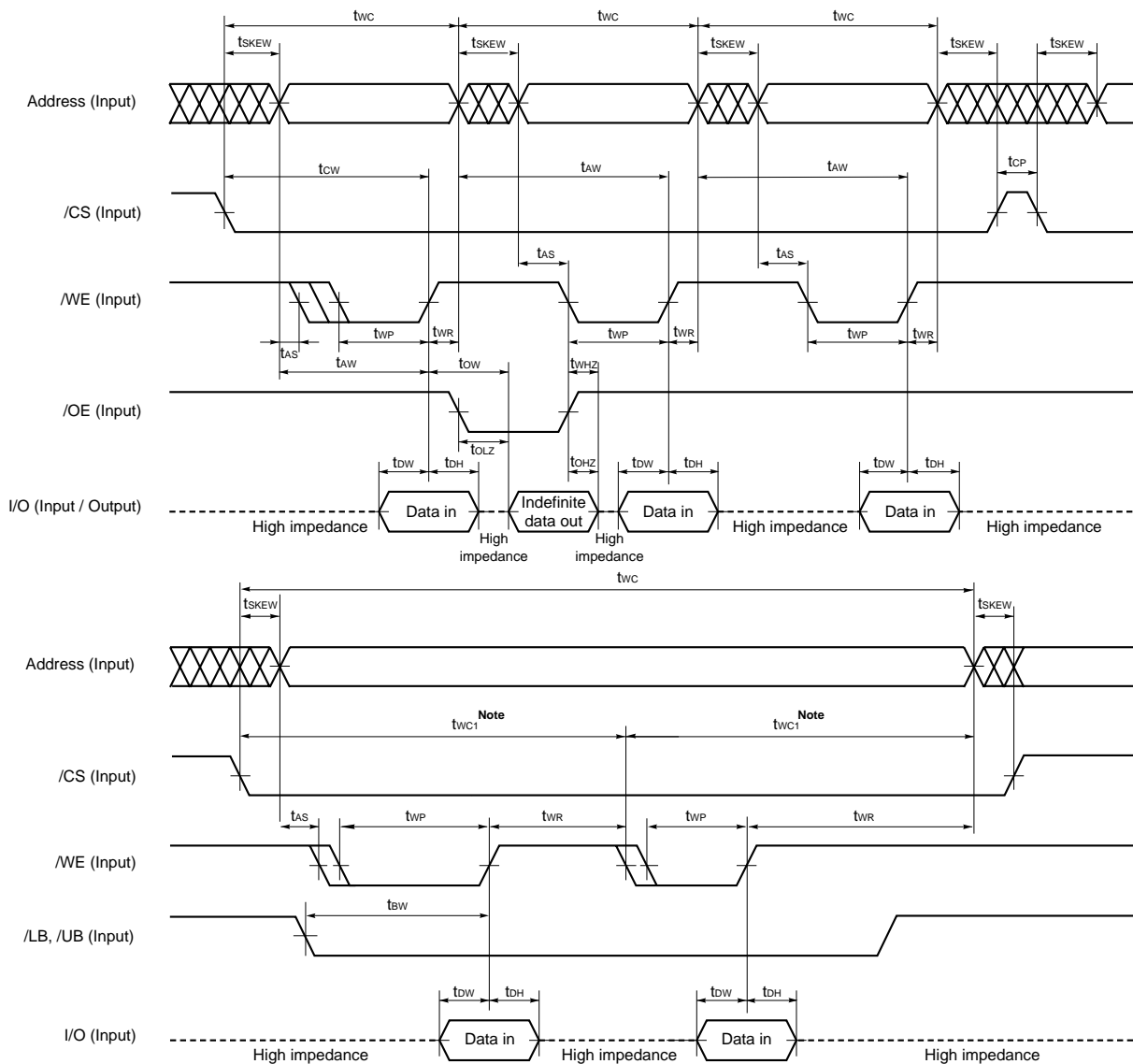

- Cautions**
1. During address transition, at least one of pins /CS, /WE should be inactivated.
 2. Do not input data to the I/O pins while they are in the output state.
 3. If the address is changed using a value that is either lower than the minimum value or higher than the maximum value for the write cycle time (twc), none of the data can be guaranteed.

Note If /LB and /UB are changed at the same time with /CS low level and a continuous write operation toggling /WE is performed, make settings so that the sum (twc) of the identical address write cycle time (twc1) is 10 μs or less.

- Remarks**
1. Write operation is done during the overlap time of a Low /CS, /WE, /LB and/or /UB.
 2. When /WE is at Low, the I/O pins are always high impedance. When /WE is at High, read operation is executed. Therefore /OE should be at High to make the I/O pins high impedance.

Write Cycle Timing Chart 3 (/CS Controlled)

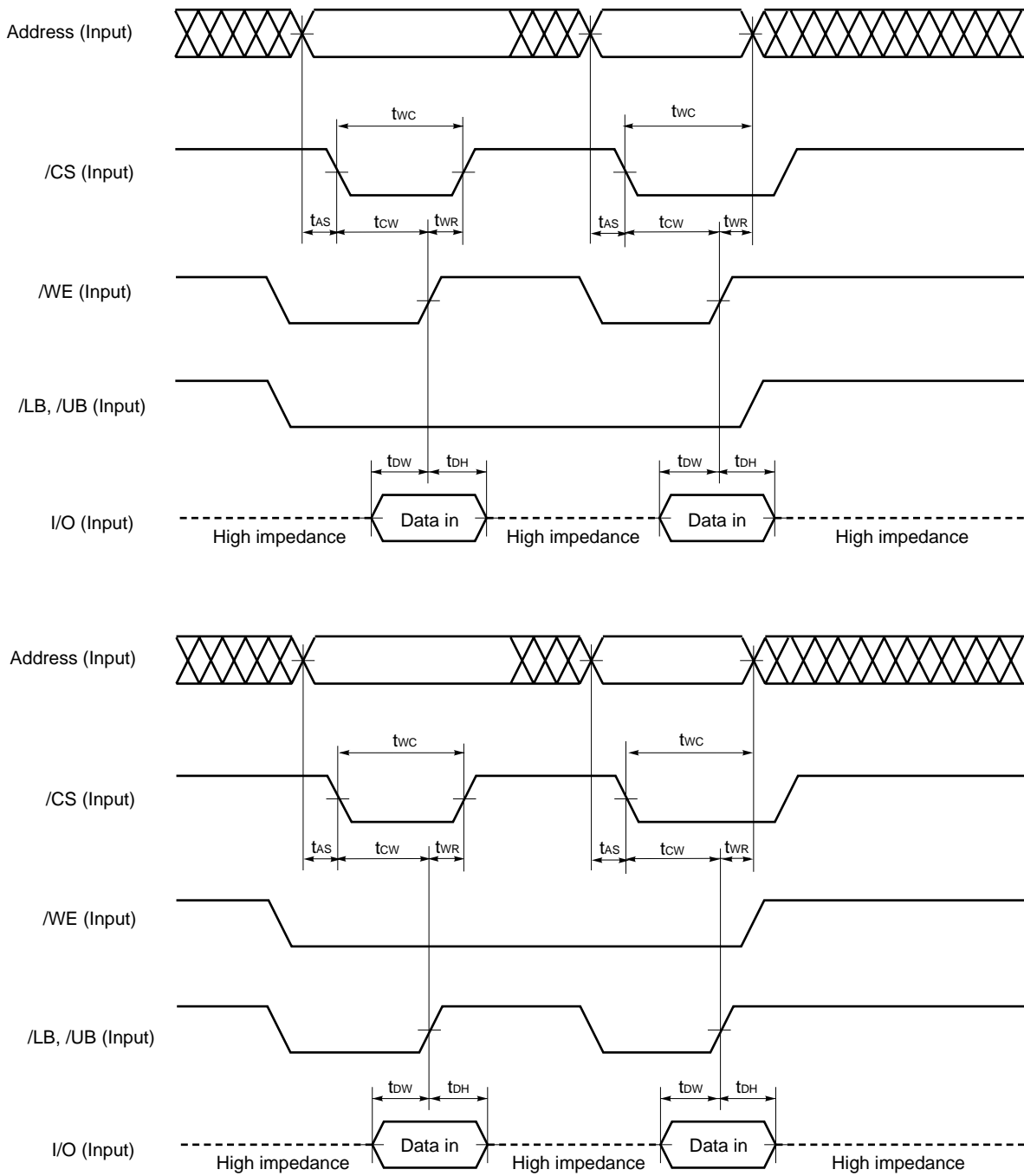

- Cautions**
1. During address transition, at least one of pins /CS, /WE should be inactivated.
 2. Do not input data to the I/O pins while they are in the output state.
 3. If the address is changed using a value that is either lower than the minimum value or higher than the maximum value for the write cycle time (t_{WC}), none of the data can be guaranteed.

Remark Write operation is done during the overlap time of a Low /CS, /WE, /LB and/or /UB.

Write Cycle Timing Chart 4 (/LB, /UB Controlled 1)

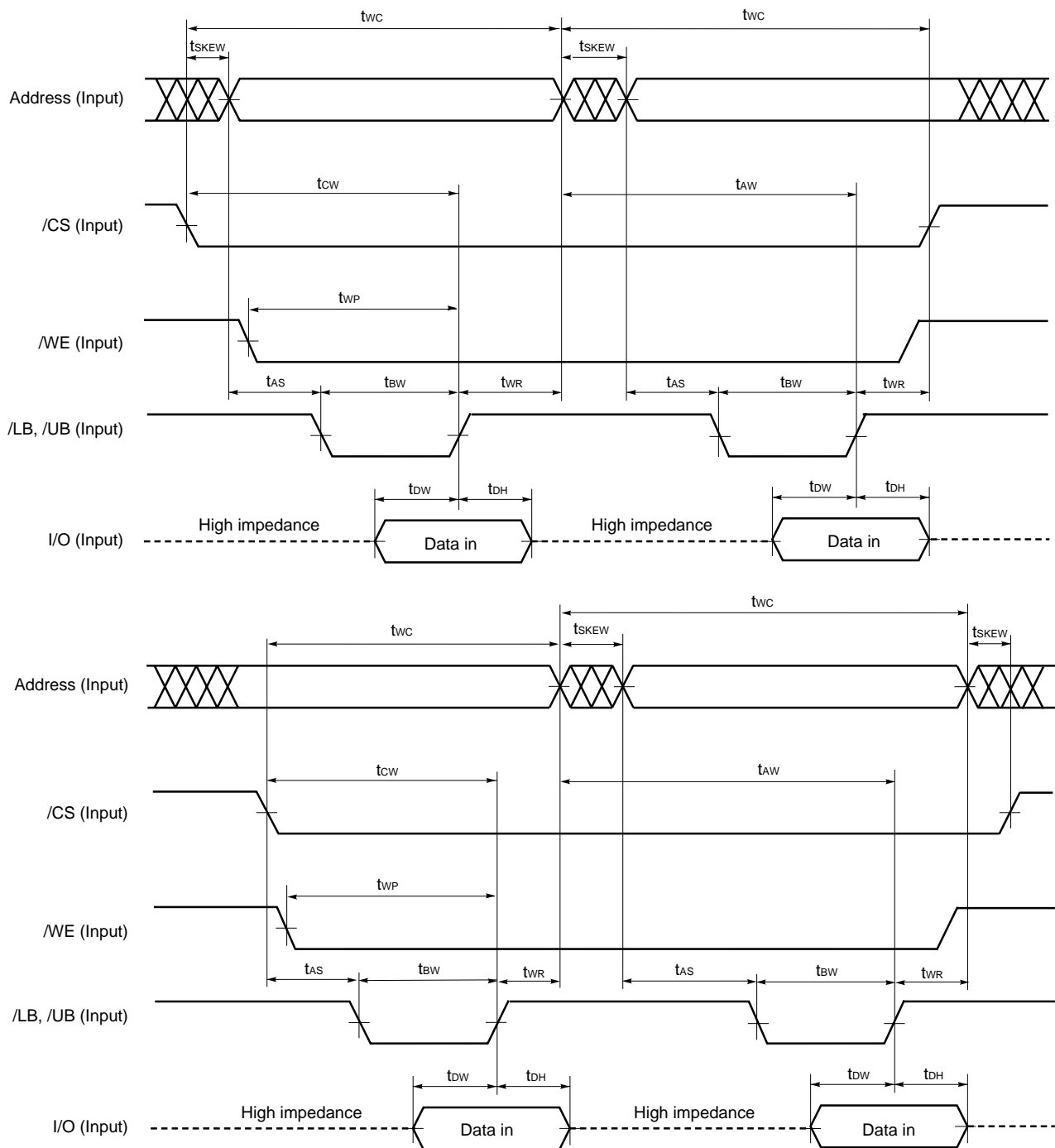

- Cautions**
1. During address transition, at least one of pins /CS, /WE should be inactivated.
 2. Do not input data to the I/O pins while they are in the output state.
 3. If the address is changed using a value that is either lower than the minimum value or higher than the maximum value for the write cycle time (t_{wc}), none of the data can be guaranteed.

Remark Write operation is done during the overlap time of a Low /CS, /WE, /LB and/or /UB.

Write Cycle Timing Chart 5 (/LB, /UB Controlled 2)

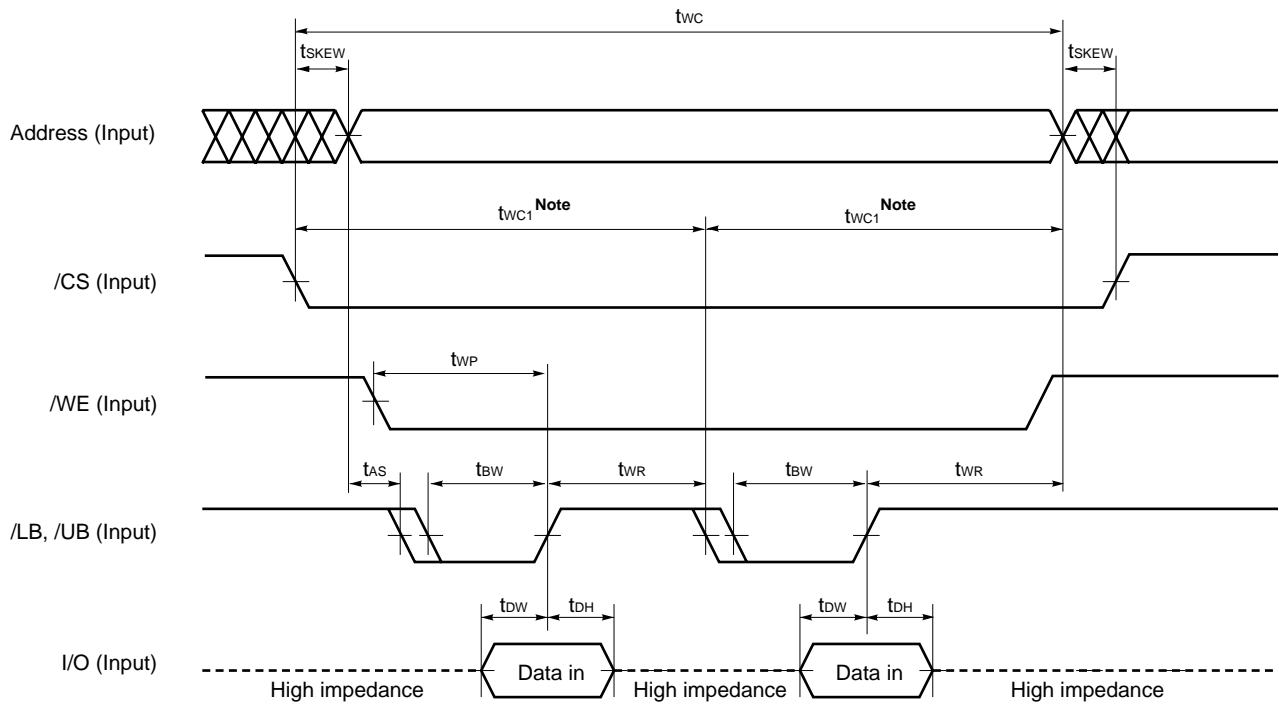

- Cautions**
1. During address transition, at least one of pins $/CS$, $/WE$ should be inactivated.
 2. Do not input data to the I/O pins while they are in the output state.
 3. If the address is changed using a value that is either lower than the minimum value or higher than the maximum value for the write cycle time (t_{WC}), none of the data can be guaranteed.

Note If $/LB$ and $/UB$ are changed at the same time with $/CS$ low level and a continuous write operation toggling $/WE$ is performed, make settings so that the sum (t_{WC}) of the identical address write cycle time (t_{WC1}) is 10 μs or less.

Remark Write operation is done during the overlap time of a Low $/CS$, $/WE$, $/LB$ and/or $/UB$.

Write Cycle Timing Chart 6 (/LB, /UB Independent Controlled 1)

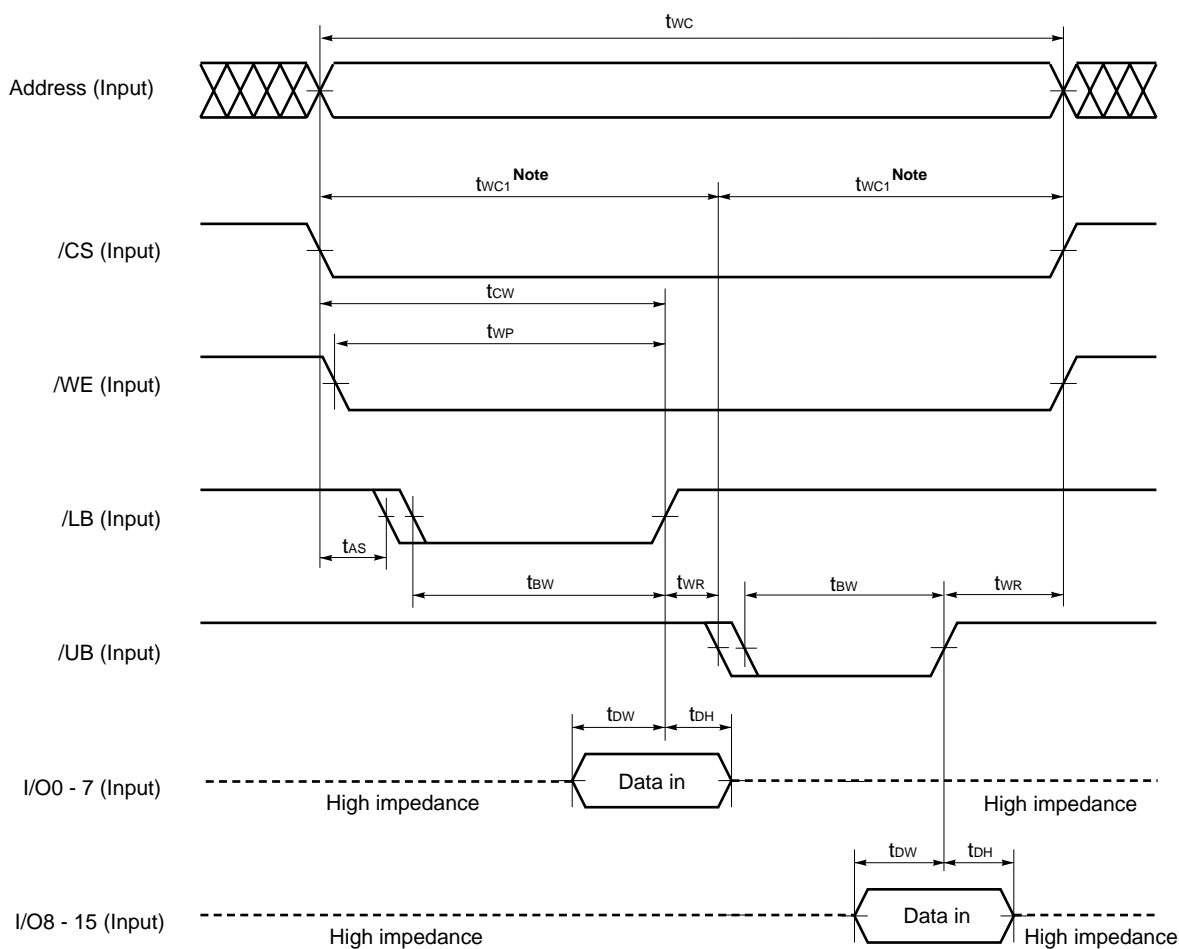

- Cautions**
1. During address transition, at least one of pins /CS, /WE should be inactivated.
 2. Do not input data to the I/O pins while they are in the output state.
 3. If the address is changed using a value that is either lower than the minimum value or higher than the maximum value for the write cycle time (t_{WC}), none of the data can be guaranteed.

Note If /LB and /UB are changed at the same time with /CS low level and a continuous write operation toggling /WE is performed, make settings so that the sum (t_{WC}) of the identical address write cycle time (t_{WC1}) is 10 μs or less.

Remark Write operation is done during the overlap time of a Low /CS, /WE, /LB and/or /UB.

Write Cycle Timing Chart 7 (/LB, /UB Independent Controlled 2)

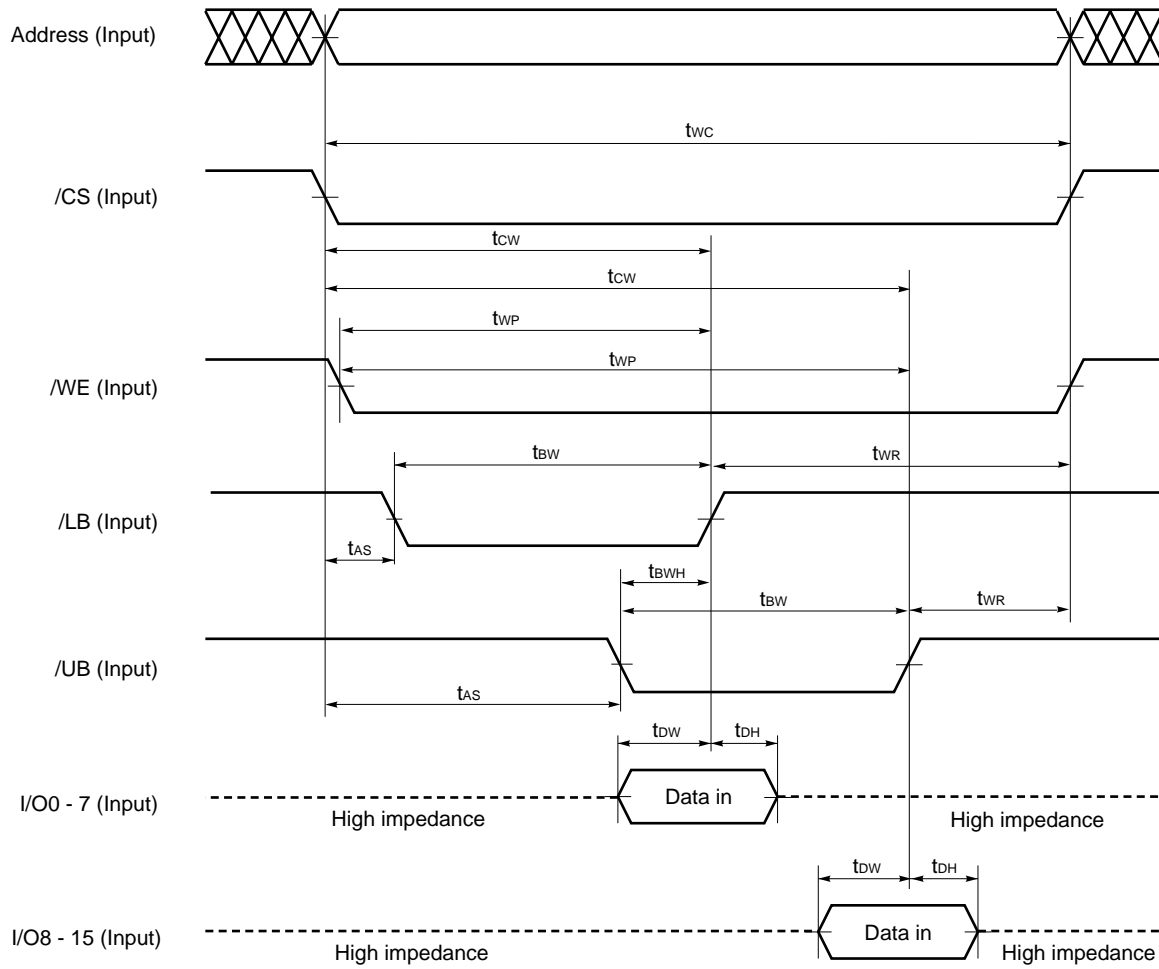

- Cautions**
1. During address transition, at least one of pins /CS, /WE should be inactivated.
 2. Do not input data to the I/O pins while they are in the output state.
 3. If the address is changed using a value that is either lower than the minimum value or higher than the maximum value for the write cycle time (t_{wc}), none of the data can be guaranteed.

Remark Write operation is done during the overlap time of a Low /CS, /WE, /LB and/or /UB.

Read Write Cycle (B version)

Parameter	Symbol	MIN.	MAX.	Unit	Note
Read write cycle time	t _{RWC}		10,000	ns	1, 2
Byte write setup time	t _{BWS}	20		ns	
Byte read setup time	t _{BRS}	20		ns	

- Notes**
1. Make settings so that the sum (t_{RWC}) of the identical address read cycle time (t_{RC1}) and the identical address write cycle time (t_{WC1}) is 10 μs or less when a write is performed at the identical address using /UB following a read using /LB with /CS low level, or when a write is performed using /LB following a read using /UB.
 2. Make settings so that the sum (t_{RWC}) of the identical address read cycle time (t_{RC1}) and the identical address write cycle time (t_{WC1}) is 10 μs or less when a read is performed at the identical address using /UB following a write using /LB with /CS low level, or when a read is performed using /LB following a write using /UB.

Read Write Cycle Timing Chart 1 (/LB, /UB Independent Controlled 1)

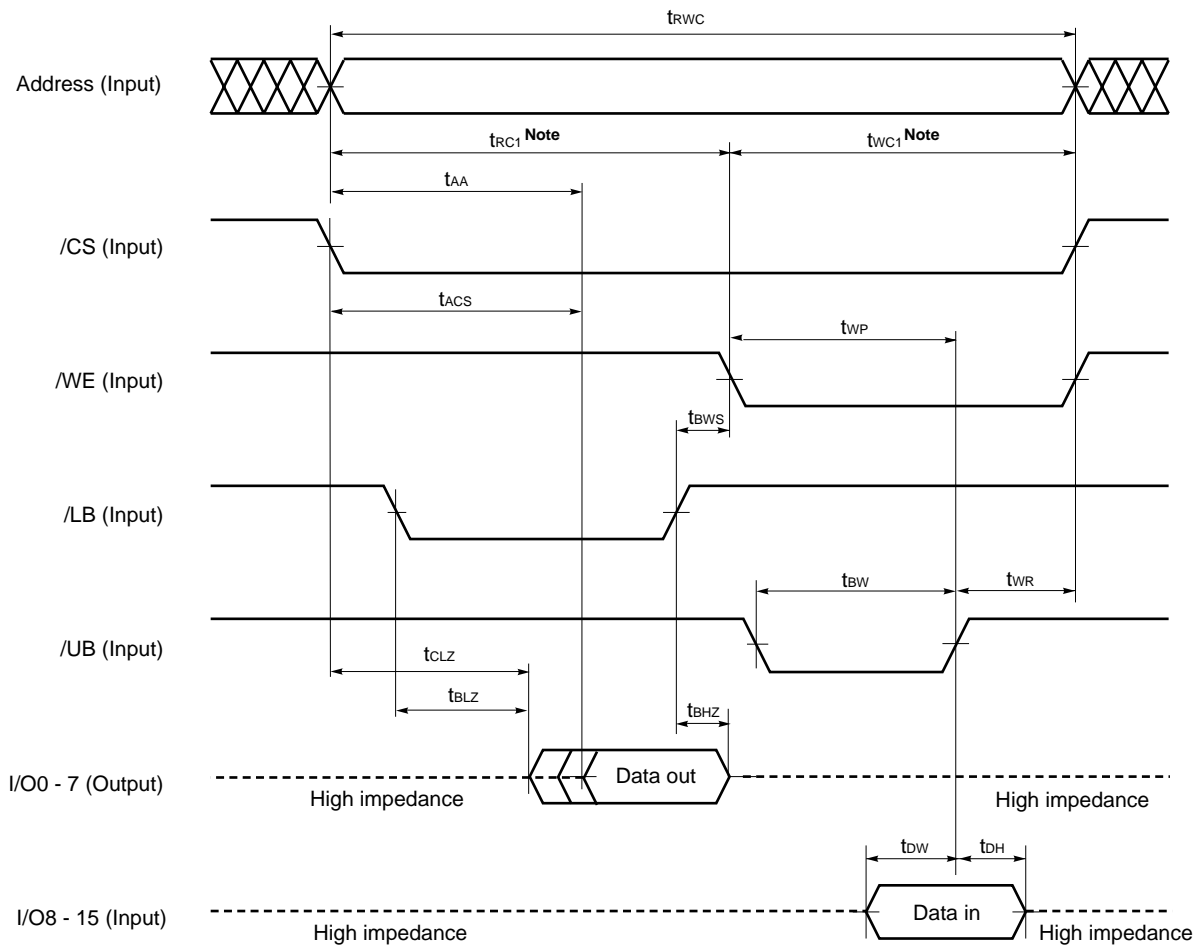

- Cautions**
1. During address transition, at least one of pins /CS, /WE should be inactivated.
 2. Do not input data to the I/O pins while they are in the output state.
 3. If the address is changed using a value that is either lower than the minimum value or higher than the maximum value for the identical address read cycle time (t_{RC1}) and the identical address write cycle time (t_{WC1}), none of the data can be guaranteed.

Note Make settings so that the sum (t_{RWC}) of the identical address read cycle time (t_{RC1}) and the identical address write cycle time (t_{WC1}) is 10 μ s or less when a write is performed at the identical address using /UB following a read using /LB with /CS low level, or when a write is performed using /LB following a read using /UB.

Remark Write operation is done during the overlap time of a Low /CS, /WE, /LB and/or /UB.

Read Write Cycle Timing Chart 2 (/LB, /UB Independent Controlled 2)

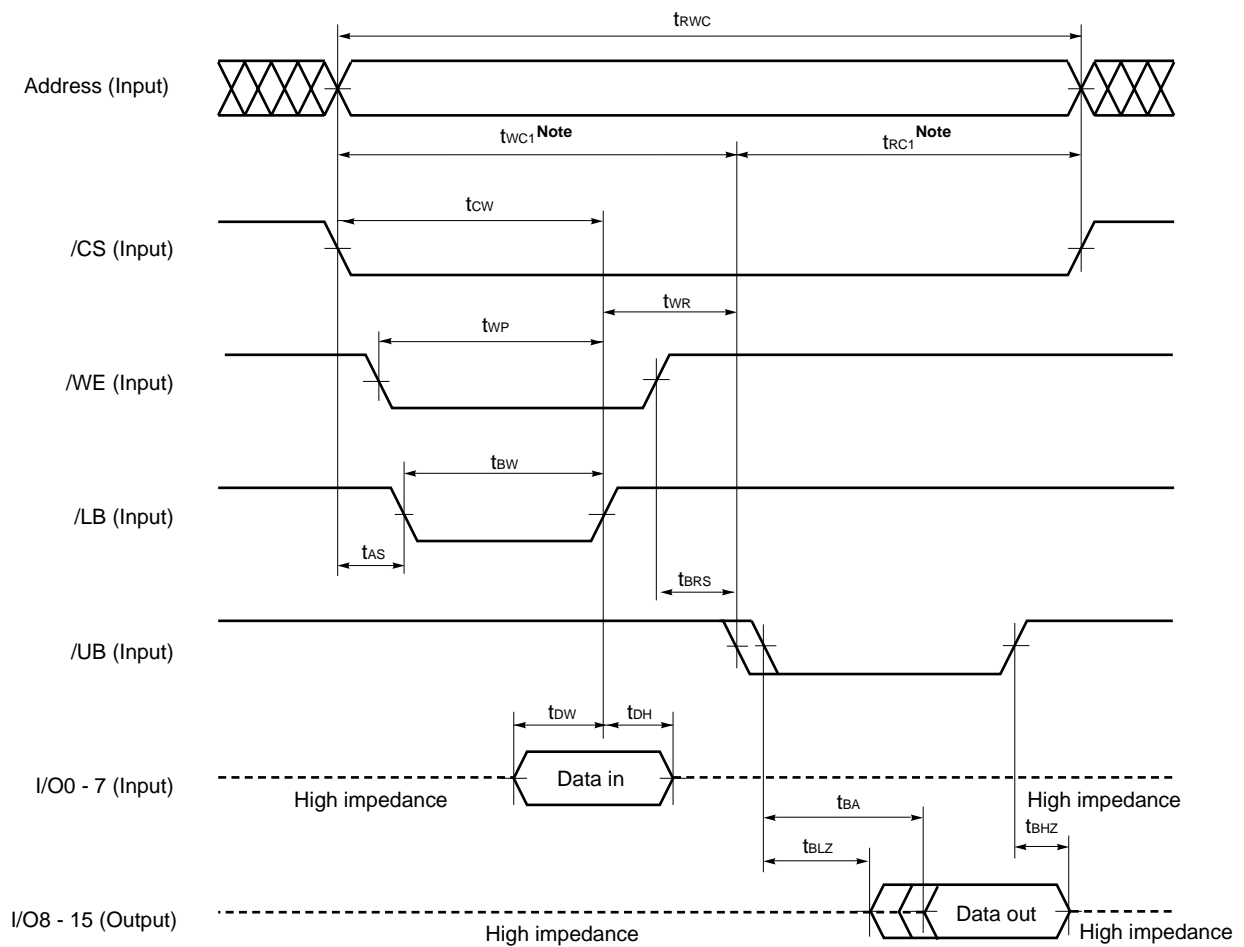

- Cautions**
1. During address transition, at least one of pins /CS, /WE should be inactivated.
 2. Do not input data to the I/O pins while they are in the output state.
 3. If the address is changed using a value that is either lower than the minimum value or higher than the maximum value for the identical address read cycle time (t_{RC1}) and the identical address write cycle time (t_{WC1}), none of the data can be guaranteed.

Note Make settings so that the sum (t_{RWC}) of the identical address read cycle time (t_{RC1}) and the identical address write cycle time (t_{WC1}) is 10 μs or less when a write is performed at the identical address using /UB following a read using /LB with /CS low level, or when a write is performed using /LB following a read using /UB.

Remark Write operation is done during the overlap time of a Low /CS, /WE, /LB and/or /UB.

Read Write Cycle Timing Chart 3 (/LB, /UB Independent Controlled 3)

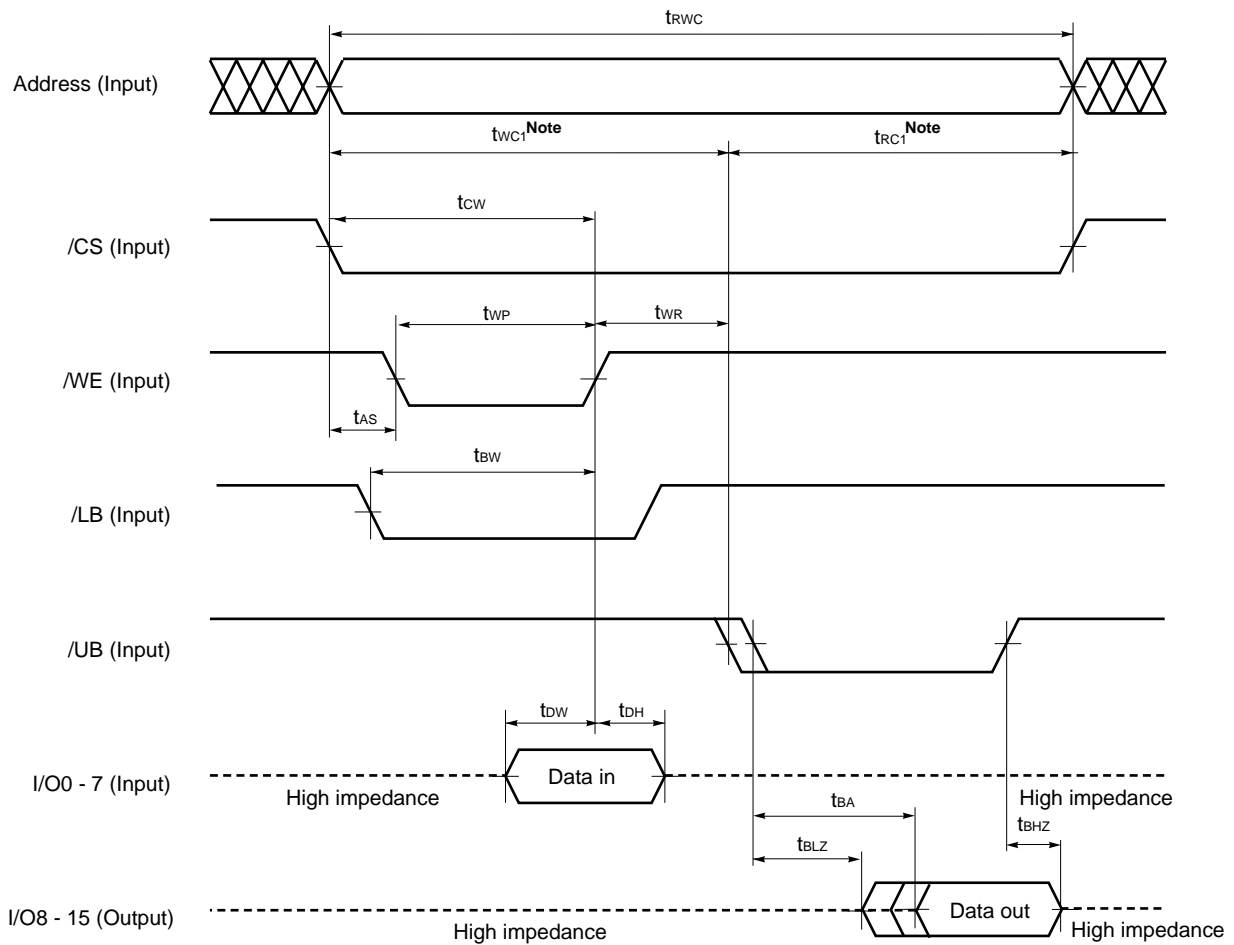

- Cautions**
1. During address transition, at least one of pins /CS, /WE should be inactivated.
 2. Do not input data to the I/O pins while they are in the output state.
 3. If the address is changed using a value that is either lower than the minimum value or higher than the maximum value for the identical address read cycle time (t_{RC1}) and the identical address write cycle time (t_{WC1}), none of the data can be guaranteed.

Note Make settings so that the sum (t_{RWC}) of the identical address read cycle time (t_{RC1}) and the identical address write cycle time (t_{WC1}) is 10 μ s or less when a write is performed at the identical address using /UB following a read using /LB with /CS low level, or when a write is performed using /LB following a read using /UB.

Remark Write operation is done during the overlap time of a Low /CS, /WE, /LB and/or /UB.

Standby Mode 2 entry and recovery Timing Chart

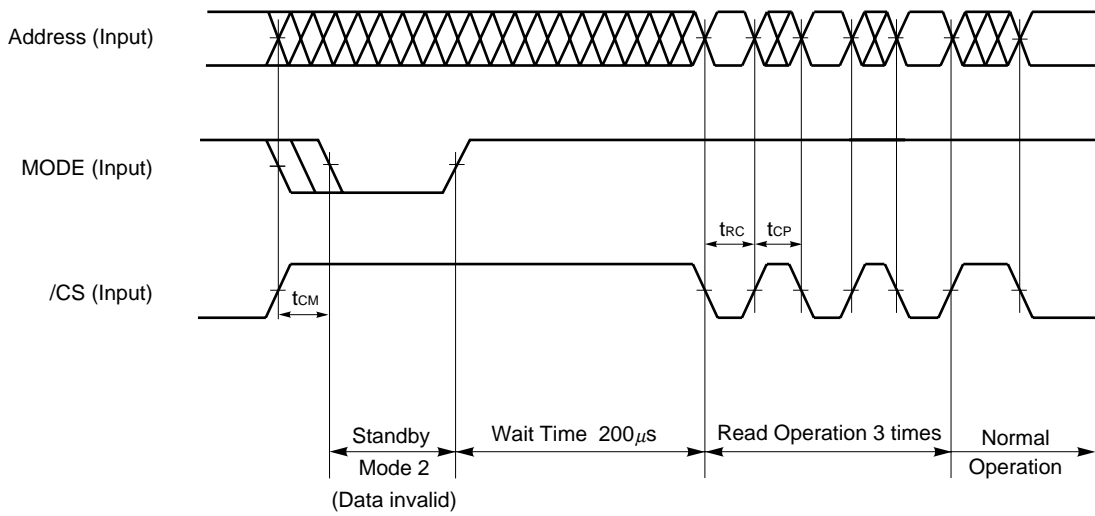

Parameter	Symbol	MIN.	MAX.	Unit	Note
/CS High to MODE Low	t_{CM}	0		ns	

- Cautions**
1. Make MODE and /CS high level during the wait time.
 2. Make MODE high level during the wait time and three read operations.
 3. The read operation must satisfy the specs described on page 10 (Read Cycle (B Version)).
 4. The read operation address can be either V_{IH} or V_{IL} .
 5. Perform reading by toggling /CS.
 6. To prevent bus contention, it is recommended to set /OE to high level.
 7. Do not input data to the I/O pins if /OE is low level during a read operation.

Package Drawing

48-PIN TAPE FBGA (8x6)

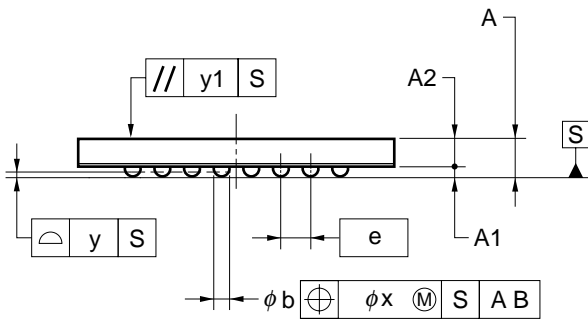
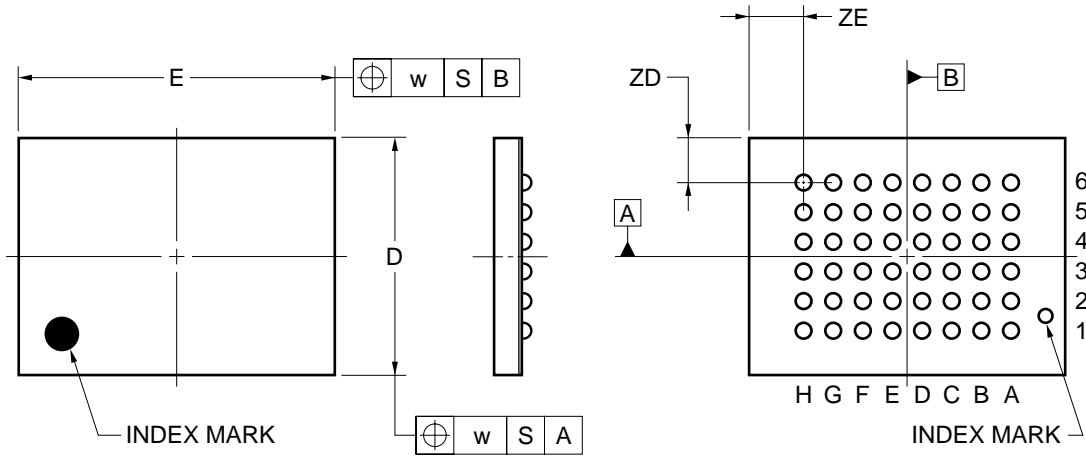

ITEM	MILLIMETERS
D	6.0±0.1
E	8.0±0.1
w	0.2
e	0.75
A	0.94±0.10
A1	0.24±0.05
A2	0.70
b	0.40±0.05
x	0.08
y	0.1
y1	0.2
ZD	1.125
ZE	1.375

P48F9-75-BC2

Recommended Soldering Conditions

Please consult with our sales offices for soldering conditions of the μ PD4616112-X.

Type of Surface Mount Device

μ PD4616112F9-BxxLX-BC2: 48-pin TAPE FBGA (8 x 6)

NOTES FOR CMOS DEVICES**① PRECAUTION AGAINST ESD FOR SEMICONDUCTORS**

Note:

Strong electric field, when exposed to a MOS device, can cause destruction of the gate oxide and ultimately degrade the device operation. Steps must be taken to stop generation of static electricity as much as possible, and quickly dissipate it once, when it has occurred. Environmental control must be adequate. When it is dry, humidifier should be used. It is recommended to avoid using insulators that easily build static electricity. Semiconductor devices must be stored and transported in an anti-static container, static shielding bag or conductive material. All test and measurement tools including work bench and floor should be grounded. The operator should be grounded using wrist strap. Semiconductor devices must not be touched with bare hands. Similar precautions need to be taken for PW boards with semiconductor devices on it.

② HANDLING OF UNUSED INPUT PINS FOR CMOS

Note:

No connection for CMOS device inputs can be cause of malfunction. If no connection is provided to the input pins, it is possible that an internal input level may be generated due to noise, etc., hence causing malfunction. CMOS devices behave differently than Bipolar or NMOS devices. Input levels of CMOS devices must be fixed high or low by using a pull-up or pull-down circuitry. Each unused pin should be connected to V_{DD} or GND with a resistor, if it is considered to have a possibility of being an output pin. All handling related to the unused pins must be judged device by device and related specifications governing the devices.

③ STATUS BEFORE INITIALIZATION OF MOS DEVICES

Note:

Power-on does not necessarily define initial status of MOS device. Production process of MOS does not define the initial operation status of the device. Immediately after the power source is turned ON, the devices with reset function have not yet been initialized. Hence, power-on does not guarantee out-pin levels, I/O settings or contents of registers. Device is not initialized until the reset signal is received. Reset operation must be executed immediately after power-on for devices having reset function.

- **The information in this document is current as of January, 2002. The information is subject to change without notice. For actual design-in, refer to the latest publications of NEC's data sheets or data books, etc., for the most up-to-date specifications of NEC semiconductor products. Not all products and/or types are available in every country. Please check with an NEC sales representative for availability and additional information.**
 - No part of this document may be copied or reproduced in any form or by any means without prior written consent of NEC. NEC assumes no responsibility for any errors that may appear in this document.
 - NEC does not assume any liability for infringement of patents, copyrights or other intellectual property rights of third parties by or arising from the use of NEC semiconductor products listed in this document or any other liability arising from the use of such products. No license, express, implied or otherwise, is granted under any patents, copyrights or other intellectual property rights of NEC or others.
 - Descriptions of circuits, software and other related information in this document are provided for illustrative purposes in semiconductor product operation and application examples. The incorporation of these circuits, software and information in the design of customer's equipment shall be done under the full responsibility of customer. NEC assumes no responsibility for any losses incurred by customers or third parties arising from the use of these circuits, software and information.
 - While NEC endeavours to enhance the quality, reliability and safety of NEC semiconductor products, customers agree and acknowledge that the possibility of defects thereof cannot be eliminated entirely. To minimize risks of damage to property or injury (including death) to persons arising from defects in NEC semiconductor products, customers must incorporate sufficient safety measures in their design, such as redundancy, fire-containment, and anti-failure features.
 - NEC semiconductor products are classified into the following three quality grades:
"Standard", "Special" and "Specific". The "Specific" quality grade applies only to semiconductor products developed based on a customer-designated "quality assurance program" for a specific application. The recommended applications of a semiconductor product depend on its quality grade, as indicated below. Customers must check the quality grade of each semiconductor product before using it in a particular application.
"Standard": Computers, office equipment, communications equipment, test and measurement equipment, audio and visual equipment, home electronic appliances, machine tools, personal electronic equipment and industrial robots
"Special": Transportation equipment (automobiles, trains, ships, etc.), traffic control systems, anti-disaster systems, anti-crime systems, safety equipment and medical equipment (not specifically designed for life support)
"Specific": Aircraft, aerospace equipment, submersible repeaters, nuclear reactor control systems, life support systems and medical equipment for life support, etc.
- The quality grade of NEC semiconductor products is "Standard" unless otherwise expressly specified in NEC's data sheets or data books, etc. If customers wish to use NEC semiconductor products in applications not intended by NEC, they must contact an NEC sales representative in advance to determine NEC's willingness to support a given application.
- (Note)
- (1) "NEC" as used in this statement means NEC Corporation and also includes its majority-owned subsidiaries.
(2) "NEC semiconductor products" means any semiconductor product developed or manufactured by or for NEC (as defined above).